

Classic Instruments

1933 – 1934

Ford

Installation Manual

Table of Contents

Welcome from the Team at Classic Instruments!	3
Mount New Gauge Cluster.....	4
Instrument Cluster Wiring.....	5
Instrument Cluster Wiring Diagram.....	6
Pulse Signal Generator [SN16F] Wiring.....	7
Oil Pressure Sender Installation	7
Temperature Sender Installation	8
Fuel Gauge Setup	8
Speedometer Calibration	9
Entering Calibration Mode:	9
Speedometer “Instant” Calibration:	10
Speedometer “Real-Time” Calibration:	11
Speedometer “Measured Mile” Calibration:	12
Reset Gauge Calibration to Factory Defaults:.....	12
Optional Tachometer Wiring	13
Optional Tachometer Wiring Diagram.....	14
Optional Tachometer Setup.....	14
Set Signal Type	14
Set # of Cylinder Signal Type.....	15
Optional: Set Shift Light Trigger Point	15

Welcome from the Team at Classic Instruments!

Our congratulations and appreciation for your purchase of one of the finest quality sets of specialty instruments ever produced! Your instrument set has been conceived, designed, and manufactured by Classic Instruments, Inc. in the U.S.A. Each instrument has been tested and certified for accuracy and quality before packaging and shipping.

For trouble-free installation and operation follow the instructions exactly as outlined. Your instruments were assembled to precise specifications and although each has a seven (7) year warranty covering defective parts and workmanship – this warranty will not cover instruments or sender units which have been installed incorrectly.

Follow our recommended procedures for installation and proper hookup to maintain the value and appearance of your instrument set during many future years of accurate and dependable service!

LIMITED WARRANTY

Classic Instruments, Inc. (CI) warrants to the original purchaser that any CI product manufactured or supplied by CI will be free from defects in material and workmanship under normal use and service for a period of seven (7) years from date of purchase.

Improper installation, use of sending units other than CI's or attempted repair or adjustments by other than CI shall void this warranty. Disassembly of any instruments or senders for whatever reason shall specifically void this warranty.

It's always easy to look to a part for an issue with your set. Before you conclude that a part may be bad, thoroughly check your work. Today's semiconductors and passive components have reached incredibly high reliability levels, but there is still room for error in our human construction skills. However, on rare occasions a sour part can slip through. Please be aware that testing can usually determine if the part was truly defective or damaged by assembly or usage. Don't be afraid of telling us that you "blew it", we're all human and in most cases, replacement parts are very reasonably priced.

Purchaser requesting a product to be repaired or replaced under warranty must first call CI at 1-800-575-0461 before the return of defective part. Send defective part to 826 Moll Drive, Boyne City, MI 49712, USA. Include a written description of the failure with defective part.

Purchaser agrees and accepts that under no circumstances will a warranty replacement be furnished until CI has first received, inspected, and tested the returned part.

All other warranties expressed or implied are hereby excluded including any implied warranty of merchandise and implied warranty of fitness for a particular purpose. The sole and exclusive remedy for breach of this warranty is limited to the replacement set forth above.

It is expressly agreed that there shall be no further remedy for consequential or other type of damage, including any claim for loss of profit, engine damage or injury.

TECHNICAL ASSISTANCE

1-800-575-0461

OR

Visit our website for the latest in gauge design and updates to our installation manual

www.classicinstruments.com

Mount New Gauge Cluster

- 1) Remove old gauge cluster from dash.
- 2) If you have a 1934 Ford dashboard, use the supplied template to cut a hole for the gauge cluster to fit into. (1933 Ford dashboards already have a hole for the gauge cluster)
- 3) Insert the gauge cluster into the dashboard and secure it using 2 mounting brackets.
 - a. Do not remove the nuts that come attached to the 4 mounting studs of the gauge (*they are holding the circuit board to the housing*). Use 4 additional nuts to secure the mounting brackets to the gauge cluster's mounting studs.

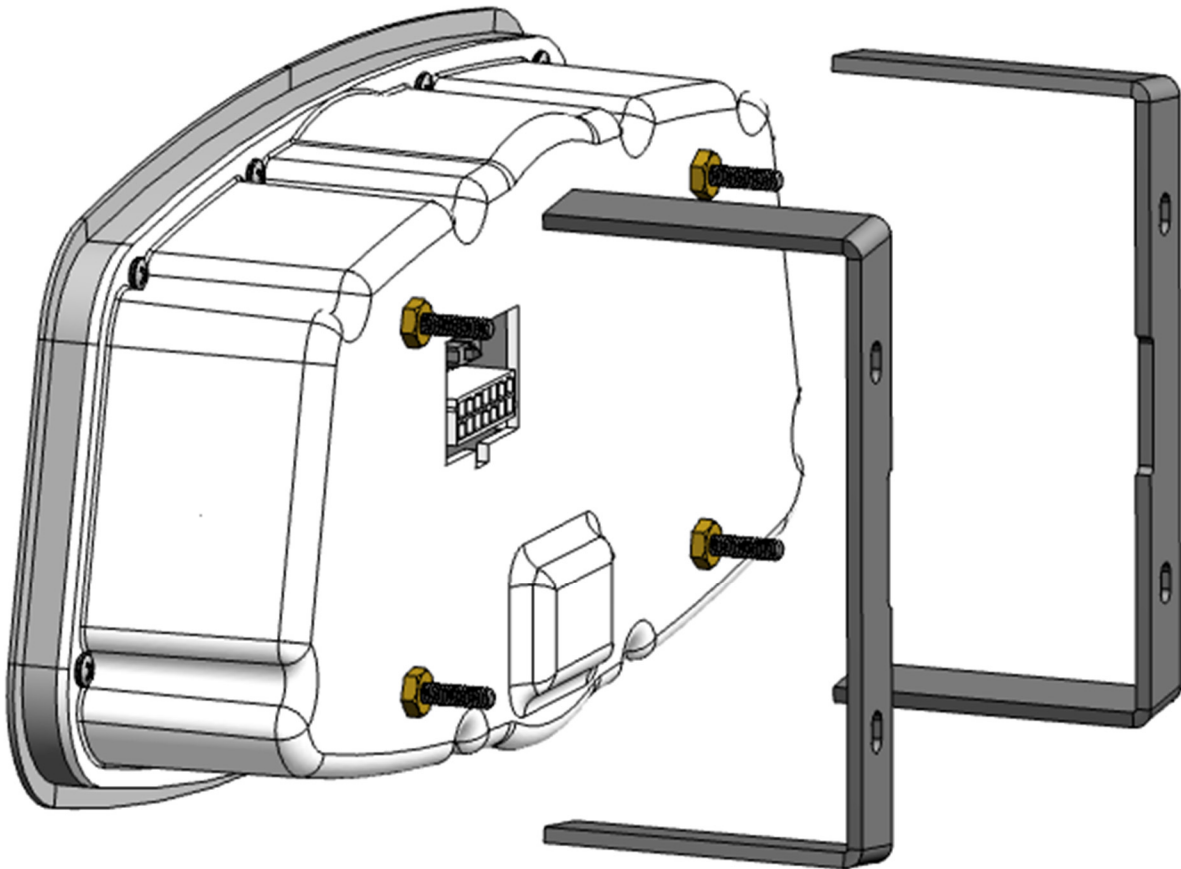

Instrument Cluster Wiring

- 1) Always disconnect the vehicle battery before wiring any gauge.
- 2) Connect a switched +12VDC power source to the **Pink** wire of the gauge wire harness. *We recommend using a dedicated power source (i.e. separate fuse on fuse panel) to avoid possible problems caused by bad “noisy” power.*
- 3) Connect a good chassis ground to the **Black** wire of the gauge wire harness. *We recommend using a dedicated chassis ground (not stacked with other ground wires) to avoid possible problems caused by a bad ground.*
- 4) Connect one of the following speed signals to the **Purple** wire of the gauge wire harness:
 - a. White signal wire from a pulse signal generator [SN16F]
 - i. *Connect the RED power wire of the SN16F to the **Red** 5V wire of the gauge wire harness.*
 - ii. *Connect the BLACK ground wire of the SN16F to a good chassis ground.*
 - [OR]
 - b. One (*either*) wire of an electronic transmission 2-wire vehicle speed sensor [VSS].
 - i. *Connect the other wire of the VSS to the same point as the Black ground wire of the gauge wire harness.*
 - [OR]
 - c. Speedometer Signal wire of a vehicle computer [PCM].
 - i. *Also set the filter switch on the back of the gauge cluster to ON.*
- 5) Connect a fuel level signal to the **Tan** wire of the gauge wire harness.
- 6) Connect a Classic Instruments temperature signal to the **Green** wire of the gauge wire harness.
- 7) Connect a Classic Instruments oil pressure signal to the **Blue** wire of the gauge wire harness.
- 8) Connect dash light power to the **Grey** wire of the gauge wire harness.
- 9) Connect high beam indicator power to the **Green / White** wire of the gauge wire harness.
- 10) Connect right turn indicator power to the **Purple / White** wire of the gauge wire harness.
- 11) Connect left turn indicator power to the **Blue / White** wire of the gauge wire harness.
- 12) Connect the **Brown** wire of the gauge wire harness to one wire of the momentary pushbutton.
 - a. *Connect the other wire of the momentary pushbutton to ground.*
- 13) *Optional:* Connect a warning indicator power the **Yellow** wire of the gauge wire harness.
- 14) *Optional:* Connect a warning indicator ground to the **White** wire of the gauge wire harness.

Instrument Cluster Wiring Diagram

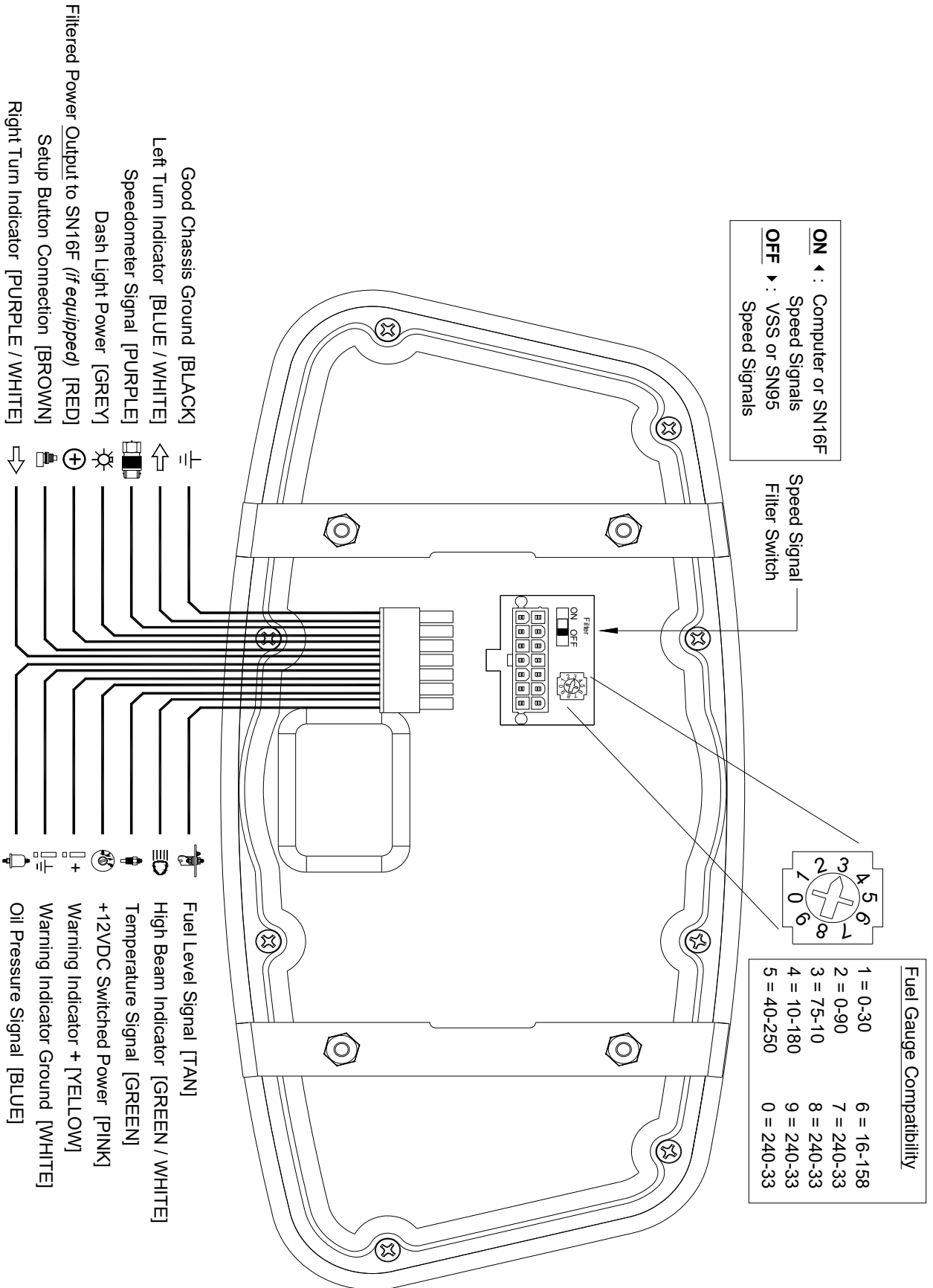

Pulse Signal Generator [SN16F] Wiring

Attach the signal generator to the transmission speedometer gear housing (where the speedometer cable originally connected). A speedometer driven gear (not supplied) needs to be installed on the transmission end of the sender. Do not use excessive force to tighten. These signal generators produce approximately 16,000 pulses per mile (PPM).

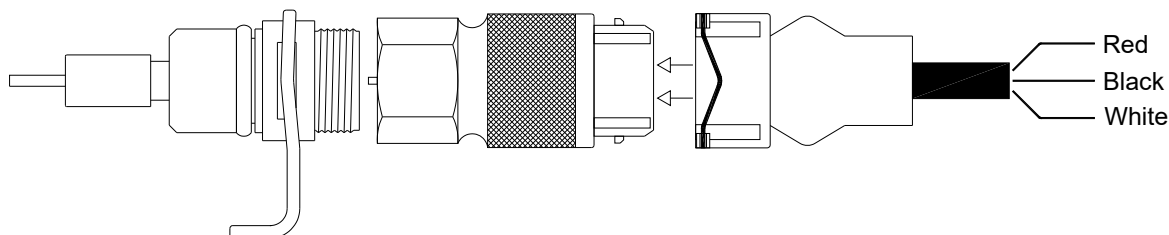

Red: ----- Power - (to *Red* wire of gauge harness)

Black: ----- Ground - (to good chassis ground)

White: ----- Signal - (to *Purple* wire of gauge harness)

Oil Pressure Sender Installation

(Part No. SN52)

- 1) Disconnect battery before installation.
- 2) Only install Classic Instruments sending units when the engine is COLD.
- 3) DO NOT use Teflon tape on the threads. These threads are slightly tapered and designed to be self-sealing. The sender uses the threads for its ground connection and sealant may cause a poor ground causing inaccurate readings. If supplemental sealant is needed, we recommend using Loctite C5-A anti-seize. This is a copper based anti-seize which will allow a good electrical connection for the sender ground.
- 4) Connect a wire from the top terminal of the oil pressure sender to the **Blue** wire of the gauge wire harness.

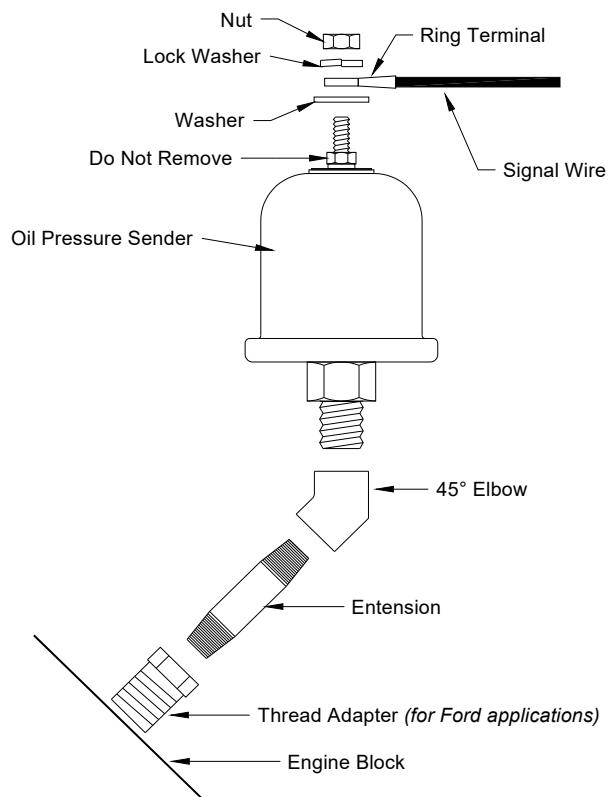

Temperature Sender Installation

(Part No. SN12MM, SN22, SN23, SN24 & SN25)

- 1) Disconnect battery before making any connections.
- 2) Install the Classic Instrument's temperature sending unit only when the engine is **COLD!**
- 3) **DO NOT** use Teflon tape on the threads. These threads are slightly tapered and designed to be self-sealing. The sender uses the threads for its ground connection and sealant may cause a poor ground causing inaccurate readings. If supplemental sealant is needed, we recommend using Loctite C5-A anti-seize. This is a copper based anti-seize which will allow a good electrical connection for the sender ground.
- 4) Install the temperature sender into the intake manifold of your engine if possible. Installing the sender in the engine cylinder head may cause inaccurate temperature readings.
- 5) Connect a wire from the top terminal of the temperature sender to the **Green** wire of the gauge wire harness.
- 6) Tighten until snug. **DO NOT OVER TIGHTEN!**

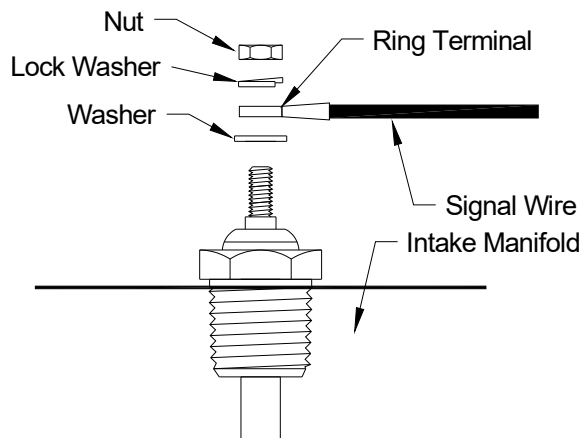

Fuel Gauge Setup

The fuel gauge can be set to work with a number of aftermarket and OEM fuel senders. Set the 10-position selector switch on the back of the gauge to match the fuel sender you are using in your tank. Below is the list of selector positions and their corresponding fuel sender compatibility. The gauge cluster comes set to option #3 to match a stock 1933-1934 Ford fuel level sender.

Selector Position	Sender Resistance Range
1	0-30 (GM Type 1964 and earlier)
2	0-90 (GM Type 1966 to 1998)
3	75-10 (Ford Type 1986 and earlier)
4	10-180 (VDO)
5	40-250 (GM Type 1998 and later)
6	16-158 (Ford Type 1987 and later)
7	240-33 (Standard Aftermarket)
8	240-33 (Standard Aftermarket)
9	240-33 (Standard Aftermarket)
0	240-33 (Standard Aftermarket)

Speedometer Calibration

Note: Before performing speedometer calibration, insure you have a good speed signal. Take a test drive and make sure the speedometer shows a speed (even though it may not be correct)! If the speedometer doesn't show a speed, troubleshoot the speed signal.

Only one calibration method is necessary to perform to calibrate the speedometer. Pick the method that works best for you.

- The "Instant" calibration method requires a GPS reference speed signal (or pace car). You will need to drive at 30mph. This method is convenient if the speedometer is more than 10mph off at a known 60mph.
- The "Real-time" calibration method requires a GPS reference speed signal (or pace car). This method allows you to drive at any known speed and make changes to the speedometer reading as you go. This method is best used if the speedometer calibration is less than 10mph off at a known 60mph.
- The "Measured Mile" calibration method requires you to drive a known mile. This is convenient when a GPS is not available to use as a reference and also if the calibration is off more than 10mph at a known 60mph. The speed at which you drive the known mile can be varied, a GPS reference or pace car is not necessary.

Calibration Modes	
Speedometer Indication	Calibration Mode
50 MPH	Speedometer "Instant" Calibration
60 MPH	Speedometer "Real-time" Calibration
70 MPH	Speedometer "Measured Mile" Calibration
80 MPH	Factory Defaults Reset Mode
90 MPH	Exit calibration Mode

Entering Calibration Mode:

- 1) Start with power to the gauge OFF.
 - 2) Press and HOLD the calibration pushbutton.
 - 3) Start engine.
 - 4) Release the pushbutton after the engine is started. The speedometer will indicate 50MPH. *The high beam indicator will also be lit [blue] to indicate that the gauge is in calibration mode.*
-

Speedometer “Instant” Calibration:

(steps 1-4 may be skipped if the gauge is already in calibration mode)

- 1) Start with power to the gauge OFF.
- 2) Press and HOLD the calibration pushbutton.
- 3) Start engine.
- 4) Release the pushbutton after the engine is started. The speedometer will indicate 50MPH. *The high beam indicator will also be lit [blue] to indicate that the gauge is in calibration mode.*
- 5) If the speedometer pointer is not at 50MPH, tap the button to cycle the pointer through the calibration modes until it comes back to 50MPH.
- 6) With the speedometer indicating 50MPH, press and hold the calibration pushbutton until the speedometer moves to 0 MPH. *The high beam indicator and turn signal indicators will flash [blue] and [green] when a speed signal is detected. If no signal is detected, only the high beam indicator will be lit a constant [blue].*
- 7) Drive the vehicle at exactly 30MPH using a GPS or pace car as a reference. Press and hold the pushbutton while traveling 30MPH. *The turn signal indicators will turn off while the button is pressed. When the calibration is completed, the speedometer will move to indicate 30MPH at which point the pushbutton may be released. The turn signal indicators will also be lit [green] to indicate a successful calibration.*
- 8) If you are satisfied with the speedometer calibration, tap the pushbutton to get back to the calibration mode options. If you would like to re-do the calibration, press and hold the pushbutton to restart the Instant Calibration process.
- 9) When you are finished, tap the pushbutton (as many times as needed) to move the speedometer pointer through the calibration modes to get to the 90MPH (Exit Calibration Mode) option. With the pointer at 90MPH, press and hold the button for about 6 seconds until the speedometer moves down and starts indicating your actual speed. The speedometer calibration is now saved. *(The turn signal indicators will remain lit until you cycle power to the gauge.)*

Speedometer “Real-Time” Calibration:

(steps 1-4 may be skipped if the gauge is already in calibration mode)

- 1) Start with power to the gauge OFF.
- 2) Press and HOLD the calibration pushbutton.
- 3) Start engine.
- 4) Release the pushbutton after the engine is started. The speedometer will indicate 50MPH. *The high beam indicator will also be lit [blue] to indicate that the gauge is in calibration mode.*
- 5) Tap the calibration pushbutton once to move the speedometer pointer up to 60MPH. *If you missed stopping the pointer at 60MPH, continue to tap the button to cycle the pointer through the calibration modes until it comes back to 60MPH.*
- 6) With the speedometer indicating 60MPH, press and hold the calibration pushbutton until the speedometer changes to 0 MPH.
- 7) Begin driving a known speed using a GPS or pace vehicle as a reference.
- 8) Press and hold the pushbutton to slowly change the indicated speed. The first time the button is pressed will increase the speedometer reading. The next time the button is pressed will decrease the speedometer reading. The speedometer will alternate between increasing and decreasing speed each time the button is pressed and held. *The high beam indicator and turn signal indicators will flash [blue] and [green] if a speed signal is detected. If no signal is detected, only the high beam indicator will be lit a constant [blue].*
- 9) Continue to press and hold the pushbutton until the speedometer is indicating the correct speed.
- 10) Once the correct speed is dialed in on the speedometer, wait 10 seconds without pressing the pushbutton *(until the turn signal indicators stop flashing and remain lit [green])* to have the current calibration saved. *If you still need to adjust the speed after this 10 second timeout, press and hold the button to re-enter the “Real Time” calibration mode again.*
- 11) If you are satisfied with the speedometer calibration, tap the pushbutton (as many times as needed) to move the speedometer pointer through the calibration modes to get to the 90MPH (Exit Calibration Mode) option. With the pointer at 90MPH, press and hold the button for about 6 seconds until the speedometer moves down and starts indicating your actual speed. The speedometer calibration is now saved. *(The turn signal indicators will remain lit until you cycle power to the gauge.)*

Speedometer “Measured Mile” Calibration:

(steps 1-4 may be skipped if the gauge is already in calibration mode)

- 1) Start with power to the gauge OFF.
- 2) Press and HOLD the calibration pushbutton.
- 3) Start engine.
- 4) Release the pushbutton after the engine is started. The speedometer will indicate 50MPH. *The high beam indicator will also be lit [blue] to indicate that the gauge is in calibration mode.*
- 5) Tap the calibration pushbutton twice to move the speedometer pointer up to 70MPH. *If you missed stopping the pointer at 70MPH, continue to tap the button to cycle the pointer through the calibration modes until it comes back to 70MPH.*
- 6) With the speedometer indicating 70MPH, press and hold the calibration pushbutton until the speedometer changes to 30 MPH.
- 7) Begin driving a known measured mile. While driving, *the high beam indicator and turn signal indicators will flash [blue] and [green] to indicate a good speed signal. If no signal is detected, only the high beam indicator will be lit a constant [blue].* The speed at which you drive the mile does not matter.
- 8) At the end of the mile, press and hold the pushbutton until the speedometer moves from 30MPH back up to 90MPH. *The turn signal indicators will be lit [green] to indicate a successful calibration. (To get a more accurate calibration, stop at the end of the mile.)*
- 9) If you are satisfied with the speedometer calibration, tap the pushbutton (as many times as needed) to move the speedometer pointer through the calibration modes to get to the 90MPH (Exit Calibration Mode) option. With the pointer at 90MPH, press and hold the button for about 6 seconds until the speedometer moves down and starts indicating your actual speed. The speedometer calibration is now saved. *(The turn signal indicators will remain lit until you cycle power to the gauge.)*

Reset Gauge Calibration to Factory Defaults:

(steps 1-4 may be skipped if the gauge is already in calibration mode)

- 1) Start with power to the gauge OFF.
- 2) Press and HOLD the calibration pushbutton.
- 3) Start engine *(or just turn the key ON).*
- 4) Release the pushbutton after the engine is started *(or the key has been turned ON).* The speedometer will indicate 50MPH. *The high beam indicator will also be lit [blue] to indicate that the gauge is in calibration mode.*
- 5) Tap the calibration pushbutton three times to move the speedometer pointer up to 80MPH. *If you missed stopping the pointer at 80MPH, continue to tap the button to cycle the pointer through the calibration modes until it comes back to 80MPH.*
- 6) With the speedometer indicating 80MPH, press and hold the calibration pushbutton until the speedometer changes to 90 MPH. *The turn signal indicators will be lit [green] to indicate the gauge has been restored to the factory default settings.*
- 7) With the speedometer pointer at 90MPH, press and hold the button for about 6 seconds until the speedometer pointer moves down to zero. *(The turn signal indicators will remain lit until you cycle power to the gauge.)*

Optional Tachometer Wiring

- 1) Always disconnect the ground lead from the vehicle battery before wiring any gauge.
- 2) Connect a switched +12VDC power source to the **Pink** wire of the tachometer harness.
- 3) Connect a good chassis ground to the **Black** wire of the tachometer harness.
- 4) Connect dash light power to the **Grey** wire of the tachometer harness.
- 5) Connect one wire of the tachometer calibration button to the **Brown** wire of the tachometer harness.
 - a. Connect the other wire of the calibration button to a good chassis ground.
- 6) Optional: Connect a remote shift light indicator's ground to the **Yellow / White** wire of the tachometer harness.
- 7) Connect tachometer signal to the **White** wire of the tachometer harness. Refer to the following list of ignition system types to help determine where to get the signal.

STANDARD POINTS & CONDENSER SYSTEM

Connect the negative side of the coil (usually marked as “-”) to the white wire of the gauge harness.

GMC – HEI (High Energy Ignition System)

Connect the “TACH” terminal on coil side of distributor cap to the white wire of the gauge harness.

MSD (Multiple Spark Discharge System)

Connect the Tach signal on the MSD box to the white wire of the gauge harness.

VERTEX MAGNETO SYSTEM

Connect the “KILL” terminal on the side of a Vertex magneto body to the white wire of the gauge harness. An external adapter such as an MSD “Pro Mag Tach Converter” #8132 may be required.

ACCEL IGNITION COILS

Connect the negative side of the coil to the white wire of the gauge harness. CAUTION! Some Accel ignition coils require the tach signal wire to be connected to the “+” terminal on the coil! PLEASE carefully read Accel's instructions before connecting ignition coil.

MALLORY IGNITION

Connect the negative terminal side of coil (usually marked as “-”) to the white wire of the gauge harness.

IMPORTANT! Some Mallory ignition systems may require you to adjust the tachometer at the 4-cylinder setting (rather than the 8-cylinder setting).

ECM TACHOMETER SIGNAL

Connect the signal wire from the ECM to the white wire of the gauge harness. When using this type of signal, you may need to set the tachometer to the 4-cylinder setting regardless of the actual cylinders on the engine. Also, set the signal type to “low voltage” when using this signal.

MULTIPLE COIL IGNITION SYSTEMS

A tach adapter is required for these ignition systems. A tach signal driver such as the MSD #8913, which produces a 12V square wave signal, is recommended along with a SN74Z signal converter. Please check with manufacturer for your specific application.

NOTICE! For all other ignition systems please look at the owner's manual for that system.

Optional Tachometer Wiring Diagram

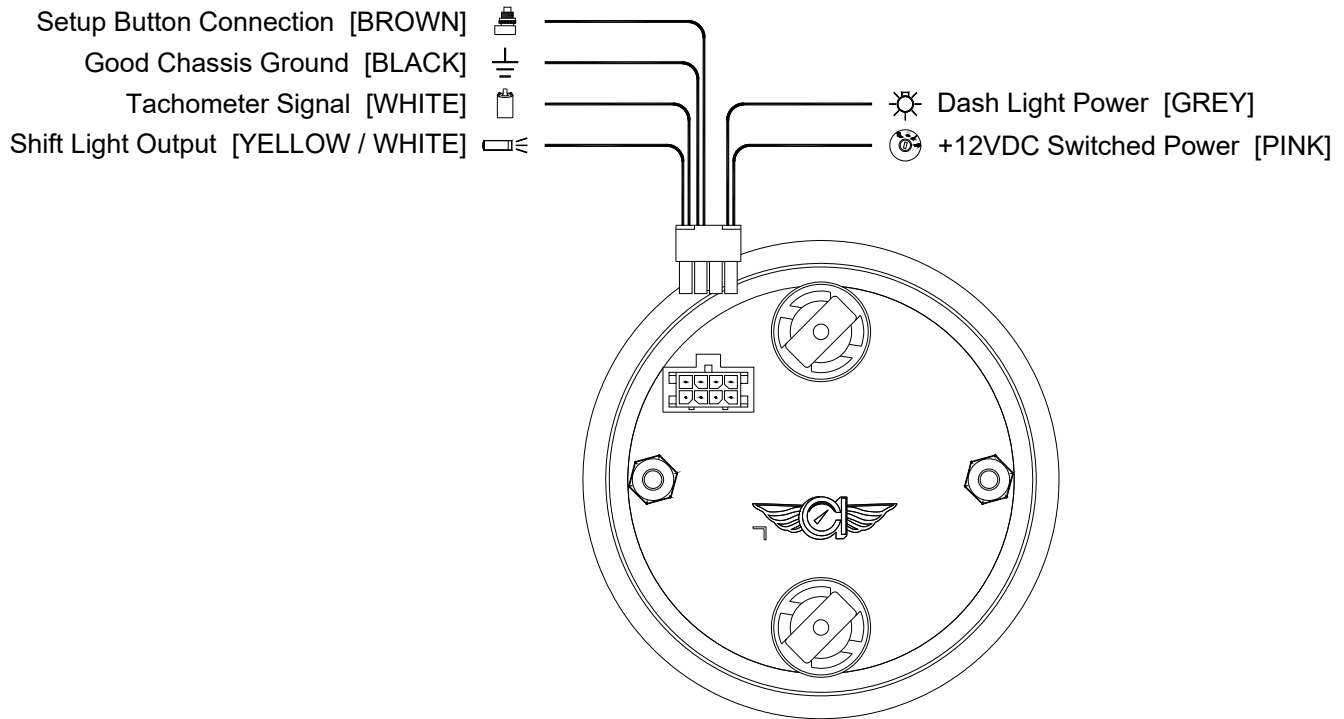

Optional Tachometer Setup

Set Signal Type:

1. Start with power off.
2. Press and hold pushbutton.
3. While pressing pushbutton, apply power to the gauge (starting vehicle not necessary).
4. Release pushbutton once power is applied.
5. Tachometer pointer will indicate 2000 RPM.
6. Press and hold the pushbutton (with tachometer reading 2000 RPM) until the pointer moves to indicate the signal type.
7. Tapping the pushbutton will cause the pointer to alternate between 5000 RPM “Low Voltage Signal” (*from an ECM*) and 6000 RPM “High Voltage Signal” (*from standard, HEI or CDI {MSD} ignitions*).
8. Press and hold the pushbutton until the pointer returns to 0 RPM to save the setting.

Set # of Cylinder Signal Type:

1. Start with power off.
2. Press and hold pushbutton.
3. While pressing pushbutton, apply power to the gauge (starting vehicle not necessary).
4. Release pushbutton once power is applied.
5. Tachometer pointer will indicate 2000 RPM.
6. Tap the pushbutton to index the pointer to 4000 RPM "4-cylinder", 6000 RPM "6-cylinder" or 8000 RPM "8-cylinder".
7. Press and hold the pushbutton with the pointer indicating the desired setting (4000, 6000 or 8000) to set the signal type. Once set, the pointer will return to 0 RPM.

Optional: Set Shift Light Trigger Point:

1. Start with power off.
2. Press and hold pushbutton.
3. While pressing pushbutton, apply power to the gauge (starting vehicle not necessary).
4. Release pushbutton once power is applied.
5. Tachometer pointer will indicate 2000 RPM.
6. Tap the pushbutton to index the pointer to 3000 RPM.
7. Press and hold the pushbutton (with tachometer reading 3000 RPM) until the pointer moves to indicate the shift light trigger point.
8. Press and hold the pushbutton to change the RPM shown. The first time the pushbutton is pressed and held, the RPM shown will increase. The second time the pushbutton is pressed and held, the RPM shown will decrease. The RPM shown will alternate between increasing and decreasing each time the pushbutton is pressed.
9. Once the correct RPM shift light trigger point is shown, wait 8 seconds without pushing the pushbutton to save the setting. The pointer will return to 0 RPM.

Important: Turn power OFF to save changes